

OZsaver™ LIGHT

4000

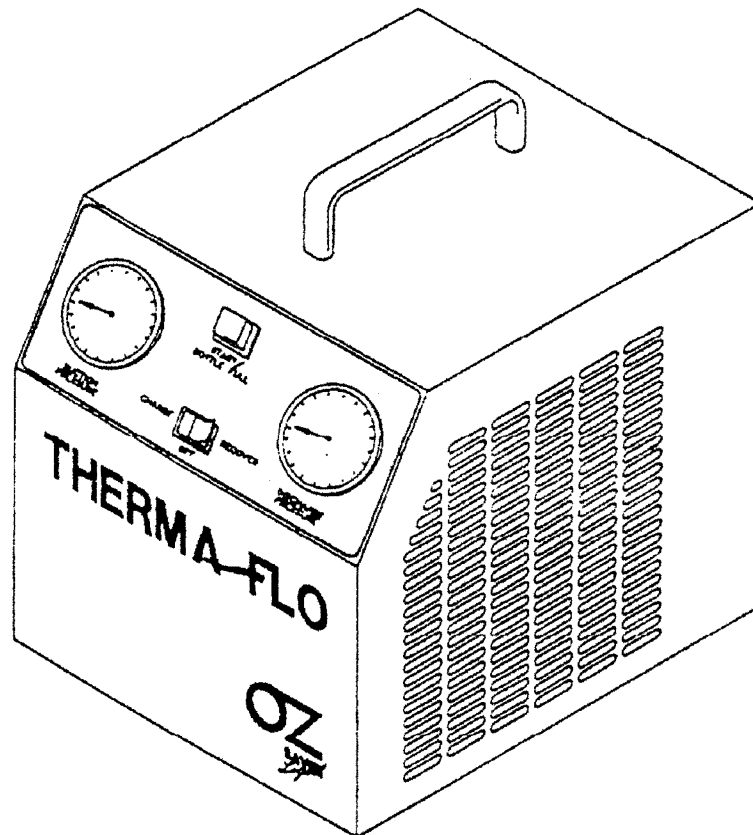

Thermaflo 88-B Industry Ave. Springfield, MA 01104
800-8484-CFC

TABLE OF CONTENTS

INTRODUCTION	1
READ ME FIRST	2
SAFETY	4
RECOVERY	
Liquid and Vapor Recovery Method	5
Push-Pull Liquid and Vapor Recovery Method	7
CHARGING OPERATION WITH HOT VAPOR	9
SELF-EVACUATION	10
SUB-COOL OPERATION	11
PURGING NON-CONDENSABLES (AIR)	11
SWITCHING FROM ONE REFRIGERANT TO ANOTHER	11
TROUBLESHOOTING	12
SCHEMATICS	14
ILLUSTRATIONS	
Figure 1 OZsaver™ <i>Light</i> Controls	3
Figure 2 Liquid and Vapor Recovery Method	6
Figure 3 Push-Pull Liquid and Vapor Recovery Method	8
Figure 4 Charging With Hot Vapor	9

UNITED STATES PATENT: 4766733
UNITED STATES PATENT: 4809515
UNITED STATES PATENT: 4981020
Other US and Foreign Patents Pending

MODEL 4000

Thermaflo • 3640 Main Street • Springfield, MA 01107
THERMAFLO is division of American THERMAFLO Corporation

Mar 1998

2436A0-

INTRODUCTION

Dear Customer:

THERMAFLO would like to thank you for selecting the OZsaver™ *Light* Recovery & Charging Unit.

THERMAFLO is dedicated to designing, producing and marketing the best products in the industry. We produce a full line of Recovery/Recycling & Charging equipment for applications in:

- HVAC
- general salvage
- refrigerated trucks
- appliance
- large industrials
- building maintenance
- automotive
- OEMS
- institutions
- automotive salvage
- mass & private transportation
- packaging & processing

Your OZsaver™ *Light* unit, like all THERMAFLO products, has gone through extensive testing to assure the highest degree of quality. THERMAFLO backs up this claim of quality with a comprehensive service program and a full warranty.

The people at THERMAFLO have put a great deal of time, effort and pride in producing this product. We believe that our continued diligence will assure better products, services and satisfied customers.

Thanks again for your confidence in THERMAFLO!

Sincerely,

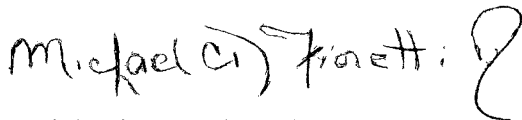

Michael C.D. Fioretti, Jr.
President

READ ME FIRST

THERMAFLO's OZsaver™ *Light* Recovery & Charging unit is a hybrid pumping system capable of moving refrigerant liquid and gas from:

- * refrigerant system being serviced to a recovery tank
- * recovery tank to system being serviced
- * new tank to a system being serviced
- * one unit to another.

The heart of the OZsaver™ *Light* unit is a compressor designed to operate without oil in its crankcase. Lubrication is a function of the materials of construction and the oil mist associated with the flow of refrigerant gas through the unit.

The compressor is a patented direct drive open style unit which can operate from **20 inches of HG** to **125 psig.** of inlet pressure. The maximum discharge pressure switch is set at **425 psig.** When 425 psig is exceeded the unit will shut down.

Since the OZsaver™ *Light* unit has a direct drive, oil-less compressor there is not a concern with overheating or harming the compressor during extended operation. In order to maximize the recovery process the OZsaver™ *Light* unit will not shut off automatically at a given low pressure - the technician **MUST** shut off the unit. This feature allows the technician the ability to pull down the system being serviced to the desired vacuum which, as a minimum, should be those required by EPA.

The OZsaver™ *Light* unit is **Approved to UL 1963** by **Underwriters Laboratories**, to recover refrigerant from any refrigerant system which uses refrigerants 12, 22, 500, 502 or 134a.

The OZsaver™ *Light* unit is **Rated in Accordance with ARI 740-91.**

Special Features

Indicator Lights - Your OZsaver™ *Light* recovery unit is equipped with High Pressure and Vapor indicating lights.

The Vapor light indicates whether the OZsaver™ *Light* unit is recovering liquid or vapor refrigerant. If the OZsaver™ *Light* unit is recovering vapor the Vapor light will be illuminated.

The High pressure light works in conjunction with the high pressure shutoff. If the discharge pressure reaches 425 psig. , the OZsaver™ *Light* unit will shut off and the High Pressure light will be illuminated.

OZsaver™ *Light* Inlet Filter

THERMAFLO requires that a THERMAFLO filter part # ALF-052, standard 052 or 053 filter drier ,or equivalent be used on the inlet side in order to protect the OZsaver™ *Light* unit from particulate damage.

If, during warranty inspection, it has been determined that a filter was not used during the operation, the OZsaver™ *Light* unit warranty will be voided.

OZsaver™ *Light* Helpful Hints

- If a service manifold is being utilized to access the equipment being serviced, the liquid must be recovered first.
- When the OZsaver™ *Light* unit is switching from liquid to vapor recovery it will make a repeated "clicking" sound. This is normal operation.
- If the system being serviced does not require valve core depressors in the hose, remove them to accelerate the recovery rate.
- Prior to use, the recovery tank should be evacuated to 1000 microns, using a vacuum pump to eliminate non-condensables and to accelerate the recovery process.
- The OZsaver™ *Light* unit has a compression ratio of 20 to 1 and can pull vacuums of 10 to 20 inches of Hg on a system even when pumping into a recovery tank with high pressures. However, it is possible to pull even deeper vacuums by replacing the storage tank with a newly evacuated storage tank at the end of the recovery process.
- If the recovery tank is partially filled with refrigerant prior to the recovery operation: it will be necessary to sub-cool the recovery tank (Refer to page 11). If the sub-cooling operation is not performed prior to the recovery operation the recovery rate will be slowed down.

The illustrations in Figure 1 are used in diagrams throughout this manual to identify items and features of the OZsaver™ *Light* unit.

SAFETY CONSIDERATIONS

PRESSURIZED tanks contain liquid refrigerant. Overfilling of the tank may cause a violent explosion and possible injury or death. The tank must be set on a calibrated scale to prevent overfilling. Use only authorized refillable tanks. *Do not recover refrigerants into a non-refillable tank.*

ALL hoses may contain liquid refrigerant under pressure. Contact with a refrigerant may cause injury. Wear proper eye and skin protective equipment. Disconnect hoses with extreme caution. Replace all worn and damaged hoses.

HIGH voltage electricity is present behind panels. Disconnect the power before servicing. Replace frayed, worn and damaged power cords.

USE with refrigerants 12, 22, 500, 502, and 134a and other replacement blends. This equipment is not designed for any purpose other than recovering or charging refrigerants.

FOR use by qualified and trained personnel only. Operator must be familiar with refrigerants and the danger of pressurized components.

FIGURE 1 OZ SAVER CONTROLS

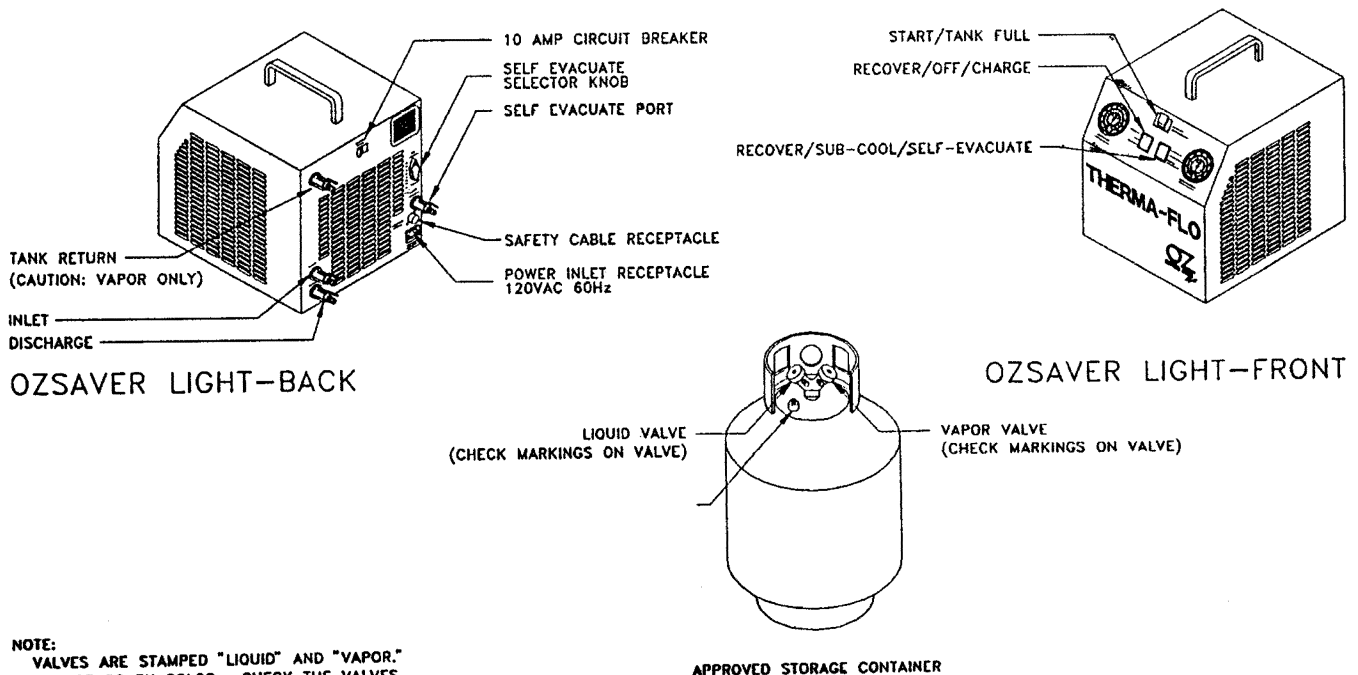

NOTE:
VALVES ARE STAMPED "LIQUID" AND "VAPOR."
DO NOT GO BY COLOR. CHECK THE VALVES.

LIQUID AND VAPOR RECOVERY METHOD

SERVICE MANIFOLD REQUIRED

(Refer to Figure 2)

Before starting this operation, an empty tank must be located on a calibrated scale. If a partially filled tank is being used, a sub-cooling operation must be performed to improve recovery performance. See page 11 for sub-cooling instructions.

1. **PLUG** in the power cord to a 110-120 VAC, 15 amp minimum supply.
 2. **CONNECT** a hose from the **INLET** port of the OZsaver™ *Light* unit to the center fitting of the service manifold. **Attention: a filter must be in this line or the warranty is voided.**
 3. **CONNECT** a hose from the **HIGH** side access port of the system being serviced to the **HIGH** side of the service manifold.
 4. **CONNECT** a hose from the **LOW** side access port of the system being serviced to the **LOW** side of the service manifold.
 5. **CONNECT** a hose from the **DISCHARGE** port of the OZsaver™ *Light* unit to the **LIQUID** side of the recovery tank.
 6. **CONNECT** a hose from the **TANK RETURN** port of the OZsaver™ *Light* unit to the **VAPOR** side of the recovery tank.
 7. **CONNECT** the Safety Cable to the Recovery Tank.
 8. **OPEN:**
 - HIGH side access valve on the system being serviced,
 - HIGH side of the service manifold,
 - DISCHARGE valve on the OZsaver™ *Light* unit,
 - INLET valve on the OZsaver™ *Light* unit,
 - TANK RETURN valve on the OZsaver™ *Light* unit,
 - LIQUID valve on the tank,
 - VAPOR valve on the tank.
 9. **TURN** the SELF-EVACUATION selector knob to OZsaver™ *Light* unit to the OFF position.
 10. **PLACE** the RECOVER/SUB-COOL/SELF EVACUATE switch in the RECOVER position.
 11. **PLACE** the Recover/Charge switch into the Recover position.
 12. **PRESS** the START button. The OZsaver™ *Light* unit will start running.
- Once all of the liquid has been recovered from the high side of the system:
13. **OPEN:**
 - LOW side access valve on the system being serviced,
 - LOW side of the service manifold.
- Once the recovery process is complete:
14. **CLOSE** all valves and place the RECOVER/OFF/CHARGE button in the OFF position.
 15. Use the SELF EVACUATION OPERATION (See Page 10) to self-evacuate the OZsaver™ *Light* unit.

FIGURE 2

LIQUID AND VAPOR RECOVERY METHOD

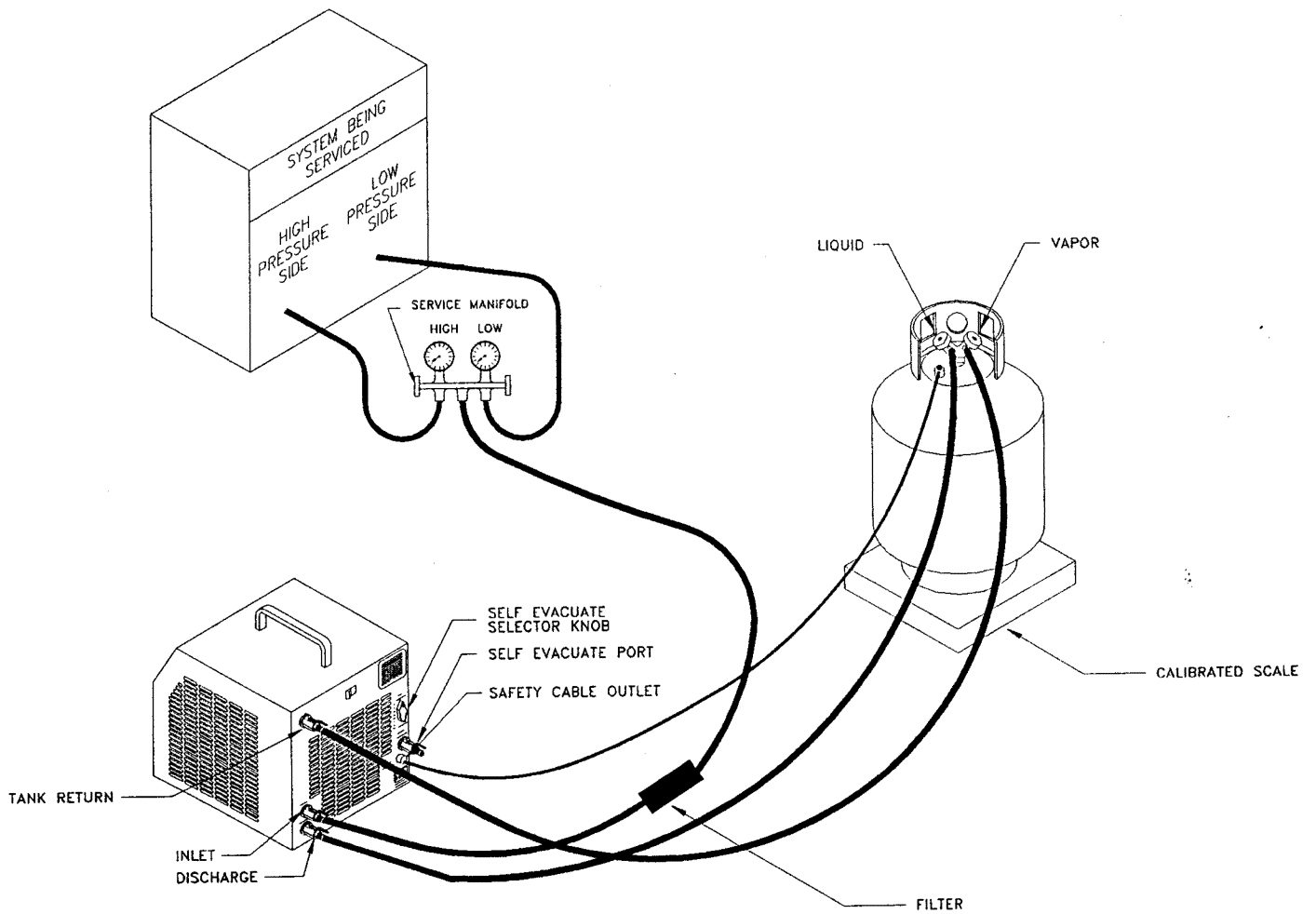

PUSH-PULL LIQUID AND VAPOR RECOVERY METHOD

(Refer to Figure 3)

If a partially filled tank is being used, a sub-cooling operation must be performed to improve recovery performance. See page 11 for sub-cooling instructions.

1. **PLUG** in the power cord to a 110-120 VAC 15 amp. minimum supply.
2. **CONNECT** a hose from the INLET port of the OZsaver™ *Light* unit to the HIGH side access port of the system being serviced. **A filter must be in this line or the warranty is voided.**
3. **CONNECT** a hose from the SELF EVACUATE port of the OZsaver™ *Light* unit to the LOW side access port of the system being serviced.
4. **CONNECT** a hose from the DISCHARGE port of the OZsaver™ *Light* unit to the LIQUID side of the recovery tank.
5. **CONNECT** a hose from the TANK RETURN port of the OZsaver™ *Light* unit to the VAPOR side of the recovery tank.
7. **CONNECT** the Safety Cable to the Recovery Tank.
8. **PLACE** the SELF-EVACUATION selector knob in the ON position.
9. **OPEN:**
 - HIGH side access valve on the system being serviced,
 - LOW side access valve on the system being serviced,
 - SELF EVACUATE valve on the OZsaver™ *Light* unit,
 - TANK RETURN valve on the OZsaver™ *Light* unit,
 - INLET valve on the OZsaver™ *Light* unit,
 - DISCHARGE valve on the OZsaver™ *Light* unit,
 - LIQUID valve on the recovery tank,
 - VAPOR valve on the recovery tank.
10. **PLACE** the RECOVER/SUB-COOL/SELF-EVACUATE switch in the RECOVER position.
11. **PLACE** the RECOVER/OFF/CHARGE switch into the Recover position.
12. **PRESS** the START button.

Once all of the liquid has been recovered:

13. **PLACE** the SELF EVACUATE selector knob in the OFF position.

The OZsaver™ *Light* unit will now be recovering vapor.

Once the vapor recovery process is complete:

14. **CLOSE** all valves and **PLACE** the RECOVER/OFF/CHARGE switch into the OFF position.

FIGURE 3

PUSH-PULL LIQUID AND VAPOR RECOVERY METHOD

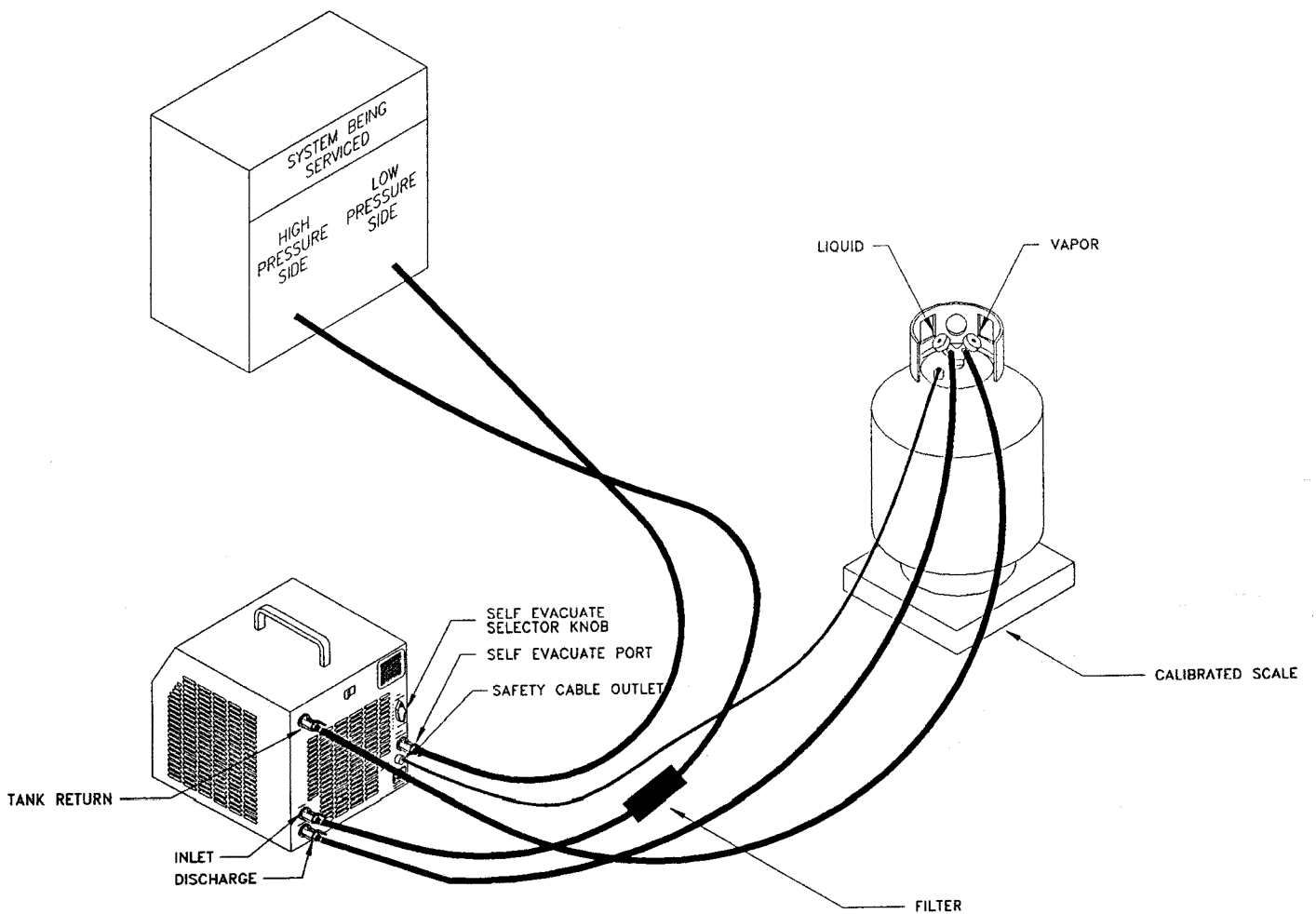

CHARGING OPERATION WITH HOT VAPOR

(Refer to Figure 4)

1. **PLUG** in the power cord (must be a 110-120 VAC, 15 amp minimum service).
 2. **CONNECT** a hose from the SELF-EVACUATE port on the OZsaver™ *Light* unit to the center port of the service manifold.
 3. **CONNECT** a hose from the TANK RETURN port on the OZsaver™ *Light* unit to the VAPOR side of the recovery tank.
 4. **CONNECT** the high side of the service manifold to the high side of the system being serviced.
 5. **CONNECT** the low side of the service manifold to the low side of the system being serviced.
 6. **TURN** the SELF-EVACUATE selector knob to the ON position.
 7. **OPEN:**
 HIGH side access valve on the system being serviced,
 LOW side access valve on the system being serviced,
 LOW side of the service manifold,
 SELF-EVACUATE valve on the OZsaver™ *Light* unit,
 TANK RETURN valve on the OZsaver™ *Light* unit,
 VAPOR valve on the recovery tank.
 8. **CLOSE:**
 INLET valve on the OZsaver™ *Light* unit,
 DISCHARGE valve on the OZsaver™ *Light* unit,
 LIQUID valve on the recovery tank,
 HIGH side of the service manifold.
 9. **PLACE** the RECOVER/SUB-COOL/SELF-EVACUATE switch into the RECOVER position.
 10. **PLACE** the RECOVER/OFF/CHARGE switch into the CHARGE position.
 11. **START** the OZsaver™ *Light* unit by pressing the START button.
- When the charging process is complete:
12. **SHUT OFF** the OZsaver™ *Light* unit.
 13. **CLOSE** all valves.

FIGURE 4
CHARGING WITH HOT VAPOR

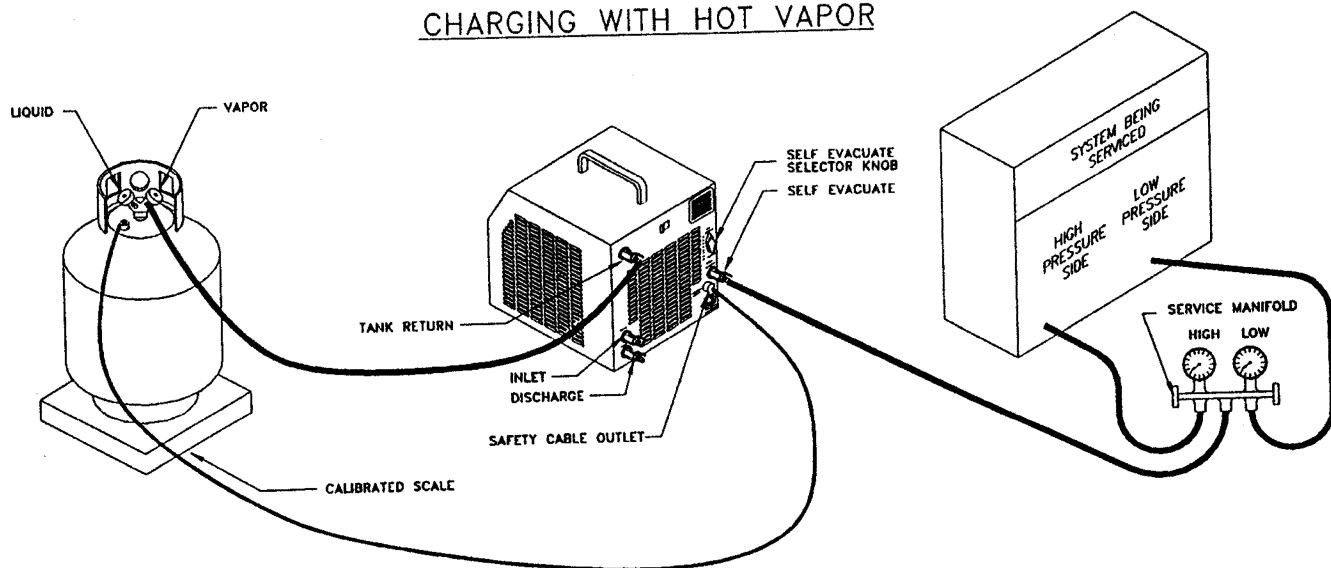

SELF-EVACUATION

1. **CLOSE** all valves, including tank valves. Make sure safety cable is connected.

If the PUSH-PULL recovery procedure is being used continue to step 2 otherwise go to step 3.

2. **REMOVE** the hose that is connected between the SELF-EVACUATE port and the LOW side of the system being serviced.
3. **PLACE** the RECOVER/SUB-COOL/SELF-EVACUATE switch into the SUB-COOL position.
4. **PLACE** the RECOVER/OFF/CHARGE switch into the Recover position.
5. **OPEN:**
TANK RETURN valve on the OZsaver™ *Light* unit,
DISCHARGE valve on the OZsaver™ *Light* unit,
LIQUID valve on the recovery tank.

6. **PRESS** the START button.

Allow the OZsaver™ *Light* unit to run until the suction pressure gauge reads 10 inches of Hg or lower, then:

7. **CLOSE:**
LIQUID VALVE ON THE RECOVERY TANK,
DISCHARGE valve on the OZsaver™ *Light* unit,
TANK RETURN valve on the OZsaver™ *Light* unit.
8. **TURN** the OZsaver™ *Light* unit off by placing the RECOVER/OFF/CHARGE switch in the OFF position.
9. **DISCONNECT** the tank return hose from the TANK RETURN port and **CONNECT** it to the SELF-EVACUATE DISCHARGE port.
10. **TURN** the SELF-EVACUATE selector knob to the ON position.
11. **OPEN:**
SELF-EVACUATE valve on the OZsaver™ *Light* unit,
VAPOR side of the recovery tank,
DISCHARGE valve on the OZsaver™ *Light* unit.
12. **PLACE** the RECOVER/SUB-COOL/SELF-EVACUATE switch into the SELF-EVACUATE position.
13. **PLACE** the RECOVER/OFF/CHARGE switch into the Recover position.
14. **START** the OZsaver™ *Light* unit by pressing the START button.
15. **ALLOW** the OZsaver™ *Light* unit to run until the suction pressure gauge reads 10 inches of Hg or lower.
16. **CLOSE** all valves.
17. **TURN** the OZsaver™ *Light* unit off by placing RECOVER/OFF/CHARGE switch into the OFF position.

SUB-COOL

The Sub-cool position on the rocker switch, located on the front of the OZsaver™ *Light* unit allows the operator to Sub-cool the storage tank when the OZsaver™ *Light* unit is connected per the standard method or when using a service manifold.

While in the Recovery Mode, move the rocker switch to Sub-cool and the OZsaver™ *Light* unit will stop recovering refrigerant from the system being serviced and Sub-cool the storage tank. This is done without having to disconnect and reconnect hoses.

When the rocker switch is in the Recover position the OZsaver™ *Light* unit returns to the normal recovery mode.

The advantages of the Sub-cool is that it allows the operator to reduce the pressure in the storage container. This enhances the recovery rates for both liquid and vapor. It also allows the OZsaver™ *Light* unit to pull exceptionally low vacuums on the systems being serviced (15 to 20 inches of Hg or better).

Sub-cooling should be done for approximately 5 to 10 minutes or until the operator feels that the pressure in the storage tank has been sufficiently reduced.

While the rocker switch is set to Sub-cool the suction pressure gage is reading the pressure in the storage container. The longer the OZsaver™ *Light* unit is Sub-cooling, the more the pressure will drop. A pressure drop of 20 psig. on the gage, from the time the Sub-cool process was begun, will result in a significant increase in the recovery rate.

PURGING NON-CONDENSABLES (AIR)

While in the Recovery mode, use the following procedure to purge the unit of air:

1. **CLOSE** the Inlet, Discharge and Tank Return valves.
2. **MOVE** the rocker switch to Self Evacuate and follow the instructions for the Self Evacuation operation described on page 10 in this manual.

NOTE: If deeper vacuums are required, a vacuum pump can be attached to the Self Evacuate Discharge valve during this process.

SWITCHING FROM ONE REFRIGERANT TO ANOTHER

Whenever the OZsaver™ *Light* unit is used on two different refrigerants, the Self Evacuation operation should be used prior to switching to the new refrigerant. The unit should then be run on air in both the Recover and Sub-cool modes for 30 seconds each to purge any residual refrigerant. A final Self Evacuation operation should then be performed to remove the air from the OZsaver™ *Light* unit.

Model 4000 Thermaflo OZ-Saver Quick Test

"Preseason Check-out"
Run this test once a year
Or

When the unit seems to run but will not move any refrigerant.

1. Plug in the power cord to 110 vac, 15 amp minimum supply.
2. Attach the safety cable to a tank sensor or use a Thermaflo test plug (Part # 1997-10).
3. TURN the SELF EVACUATE SELECTOR KNOB to the OFF position.
4. TURN the SELF EVACUATE BALL VALVE to the OFF position.
5. OPEN all (3) other ball valves.
6. Place both rocker switches into the RECOVER positions and press the START button.
7. Unit is now running.

A. The unit should be sucking in the INLET PORT. YES / NO

CLOSE: Inlet Port

B. The unit should pull a 28" vacuum on the front SUCTION GAUGE. YES / NO

OPEN: Inlet Port

Place the rocker switch in the SUB-COOL position.

C. The unit should be sucking in the TANK RETURN PORT. YES / NO

CLOSE: Tank Return Port

D. The unit should pull a 28" vacuum on the front SUCTION GAUGE. YES / NO

OPEN: Tank Return Port

Place the rocker switch back into the RECOVER position.

E. The unit should be sucking in the INLET PORT again. YES / NO

TURN the unit up-side-down on its handle

F. The unit should be sucking in the TANK RETURN PORT YES / NO

TURN the unit back up right.

CLOSE: Discharge Port

G. The unit should build 150 psi on the front DISCHARGE GAUGE within 30 seconds. YES / NO

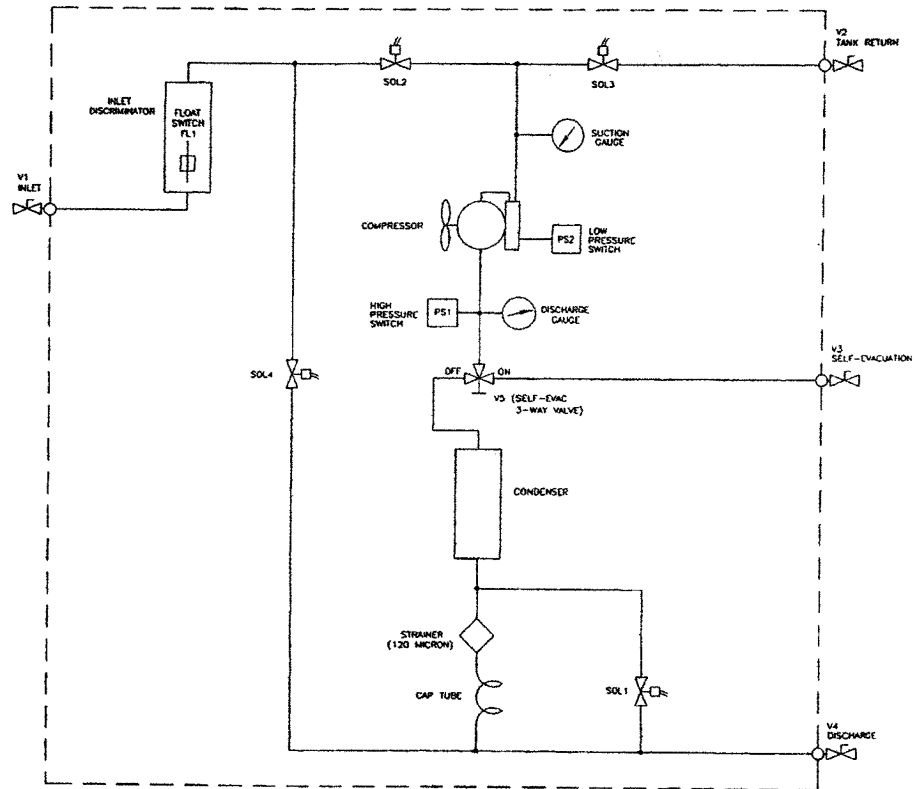

	Solenoid # 1	Solenoid #2	Solenoid #3	Solenoid #4
Liquid Recovery	Open at 20 Psig or less At Inlet	CLOSED	OPEN	OPEN
Vapor Recovery	Same	OPEN	CLOSED	CLOSED
Sub-Cool	Same	CLOSED	OPEN	CLOSED
Self-Evac	OPEN	OPEN	OPEN	OPEN

Call Thermaflo customer service at 800-848-4232
For further trouble-shooting assistance.