

INSTRUCTIONS FOR MODEL 2602 QUIK-START HERMETIC COMPRESSOR COMBINATION KIT (Includes 2601 Quik-Start & 2605 Test Lead Kit)

Model 2602 Quik-Start Combination Kit utilizes a 2601 Quik-Start to start all single phase compressors up to 5HP—110, 220, or 277 VAC and a 2605 Test Lead Kit for temporarily connecting relays, capacitors, etc., into a system for test purposes. Read these instructions carefully before using the Quik-Start.

This device is intended for use only by qualified air conditioning and refrigeration service technicians. Use extreme caution when using this unit. Make sure the system being tested is disconnected from power before connecting the Quik-Start. Do not use fuses rated higher than 30A. Read the safety precautions carefully before using.

Before using the Quik-Start, check the compressor for grounded windings. Connect an ohmmeter from the COMMON terminal to the compressor case. If the ohmmeter shows any reading less than infinity (open), the compressor is defective and the Quik-Start should not be used.

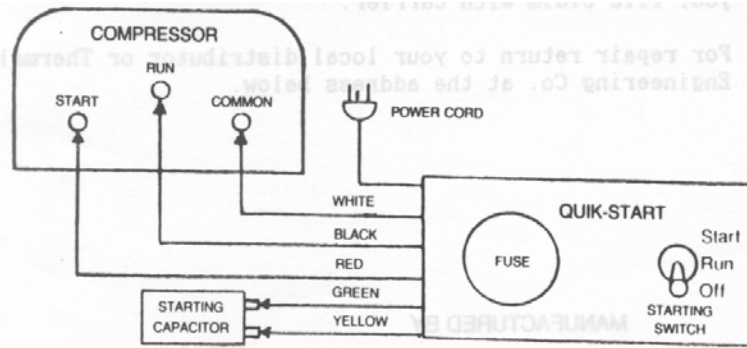

CAPACITOR START COMPRESSORS

Follow Split Phase procedure except for the YELLOW and GREEN lead connections. These leads are connected to the starting capacitor as shown-above. The capacitor can be any value and voltage equal to or greater than the original supplied with the compressor. A 200 MFD 220V capacitor will start most of the compressors in use.

ACCESSORIES

Model 2605 Test Lead Kit provides Four (4) 30 in. heavy duty test leads with colored insulated clips on each end, a 6 ft. power cord with male plug on one end and insulated clips on the other, and a 220V adaptor cord with a female receptacle on one end and insulated clips on the other.

LIMITED WARRANTY

All products sold are warranted against defects in workmanship or materials under normal use for one year. Manufacturer assumes no liability on the actual use of this equipment. Safety responsibility lies with the user.

In return for shipping the merchandise PREPAID to factory service location, Thermal Engineering Company will make a good faith effort for prompt disposition regarding any product which proves to be defective whether in or out of warranty. A complete description of the problem should be included. If product is damaged in transit to you, file a claim with the carrier.

For repair return to your local distributor or Thermal Engineering.

Thermal Engineering Company
A division of Airserco Manufacturing Company
7555 Tyler Blvd.—Unit 1
Mentor, OH 44060
USA
www.thermalengineeringcompany.com

Thermal Engineering Company
A division of Airserco Manufacturing Company
7555 Tyler Blvd.—Unit 1
Mentor, OH 44060
USA
www.thermalengineeringcompany.com

Safety Precautions

1. Do not use fuses rated higher than 30A. The use of larger fuses could endanger the operator and will void the warranty.
2. Disconnect the system being tested from power before using the Quik-Start.
3. Make all required connections to the compressor and components before connecting the Quik-Start to power.
4. Do not touch the compressor case when using the Quik-Start.
5. Do not attempt to use the Quik-Start if the compressor windings are grounded.
6. When using the 220V adaptor leads from the Model 2605 Test Lead Kit, do not attach the green ground wire to the compressor case. Use a proper ground only.
7. Before removing the system wiring and before removing Quik-Start leads after testing, discharge capacitors by shorting across the capacitor terminals with a screw driver or test lead. Soldering a 15000 ohm 1 watt resistor across the capacitor terminals will automatically discharge the capacitor without altering its performance.

COMPRESSOR TERMINAL IDENTIFICATION

The compressor terminals can be identified by using an ohmmeter set to OHMS X 1 and measuring the resistance between terminals.

1. Find the two terminals that give the highest resistance reading. The remaining terminal is COMMON.
2. Find the two terminals with the lowest resistance. The remaining terminal is START.

Thermal Engineering Company
A division of Airserco Manufacturing Company
7555 Tyler Blvd.—Unit 1
Mentor, OH 44060
USA
www.thermalengineeringcompany.com

3. The remaining unidentified terminal is RUN.

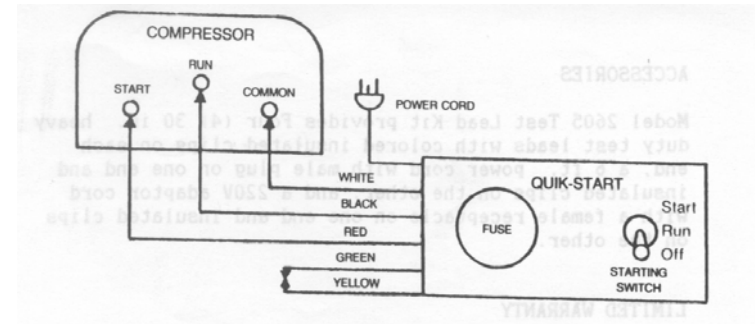

SPLIT PHASE COMPRESSORS

1. Set Quik-Start STARTING switch to the OFF position.
2. Connect the leads as shown above. The GREEN and YELLOW leads are connected together.
3. Plug in Quik-Start power cord to grounded outlet. For 220V compressors use adaptor leads from 2605 kit.
4. Push STARTING switch to START position and hold.
5. Release STARTING switch when compressor starts. The switch will remain in the RUN position until manually turned to OFF. If compressor does not start, turn STARTING switch to OFF.

Thermal Engineering Company
A division of Airserco Manufacturing Company
7555 Tyler Blvd.—Unit 1
Mentor, OH 44060
USA
www.thermalengineeringcompany.com