

GT-MM1 PARTS DIAGRAM

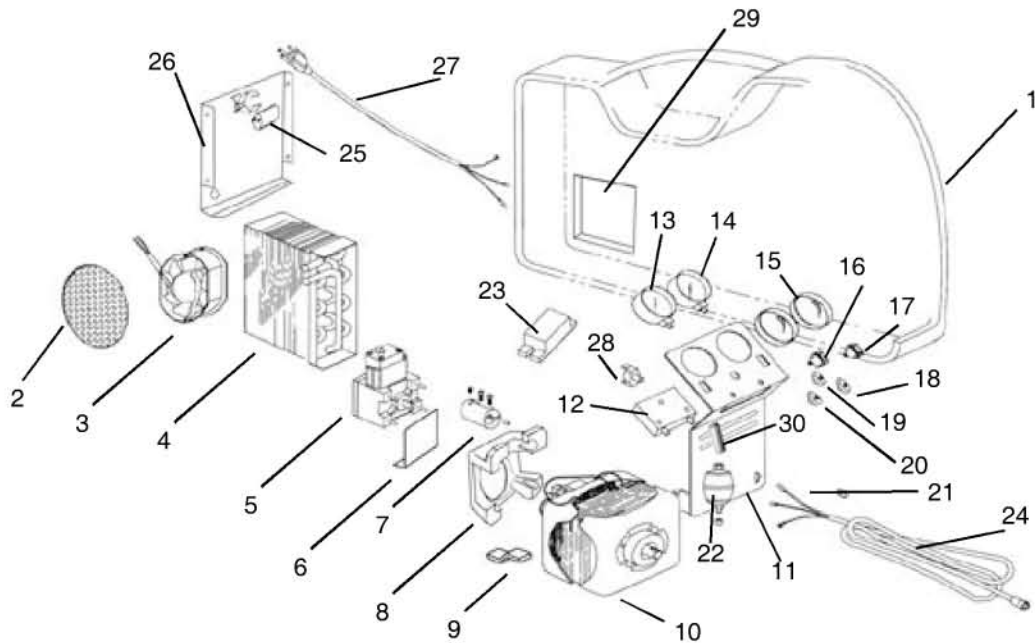

GT-MM1 PARTS LIST

ITEM	DESCRIPTION	PART#	11	FRONTPANEL	(100121)	22	FILTER	(100343)
1	PLASTIC CASE	(100118)	12	MANIFOLD	(700009)	23	*RELAY	(EL1500)
2	FAN GRILL, OUTLET	(100179)	13	INPUT GAUGE	(GA1500)	24	*SENSOR CORD	(EL1420)
3	AXIAL FAN	(100119)	14	OUTPUT GAUGE	(GA0800)	25	CAPACITOR	(EL1412)
4	CONDENSER	(100139)	15	GAUGE LENS	(GA1000)	26	REAR PANEL	(100221)
5	COMPRESSOR	(CP1320)	16	ON/OFF SWITCH	(EL1310)	27	CORD SET	(100162)
6	COMPRESSOR BRACKET	(100207)	17	STARTSWITCH	(EL1309)	28	PRESSURE SWITCH	(EL2802)
7	COUPLER	(CP1315)	18	RED KNOB	(100124)	29	FAN GRILL, INLET	(100180)
8	BELL HOUSING	(CP1001)	19	BLACK KNOB	(100122)	30	HOSEASSY	(100345)
9	MOTOR BRACKET	(100209)	20	BLUE KNOB	(100123)			
10	MOTOR	(EL1821)	21	FLARE CAP	(NB6501)			

*OPTIONAL COMPONENTS FOR 80% CAPACITY TANK SENSING KIT

REPLACEMENT KITS & ACCESSORIES

PART#	DESCRIPTION
KT3302	PISTON SEAL REPLACEMENT (middle section of compressor)
KT3303	VALVE REPLACEMENT KIT (top section of compressor)
KT3307	COMPRESSOR REPAIR KIT (all three sections of compressor)
KT3308	SHAFT REPLACEMENT KIT (bottom section of compressor)
KT5001	80% CAPACITY TANK SENSING KIT
RGT30	30 LB RECOVERY TANK (350 psi working pressure) with capacity sensor
RGT30NS	SAME AS RGT30, WITHOUT SENSOR
RGT50	50 LB RECOVERY TANK (350 psi working pressure) with capacity sensor
RGT50NS	SAME AS RGT50, WITHOUT SENSOR
RGT50HP	50 LB RECOVERY TANK, HIGH PRESSURE(400 psi working pressure) with capacity sensor
ADS-100	REFRIGERANT SCALE, 200LB CAPACITY, WITH REMOVABLE PLATFORM